

Instructions for use



Junior 3000

REF 077-000-00

REF 077-000-01

Features and controls

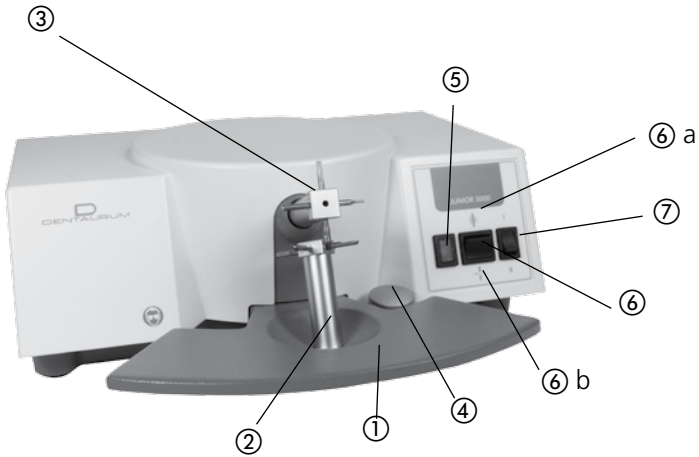

- ① Handrest with electrode opening mechanism
- ② Lower click-stop electrode holder
- ③ Upper click-stop electrode holder
- ④ Manual button
- ⑤ On/Off light
- ⑥ Switch for selecting "Welding" (weld symbol ⑥a) or "Soldering" (solder symbol ⑥b) mode
- ⑦ Switch for selecting welding power (I or II)

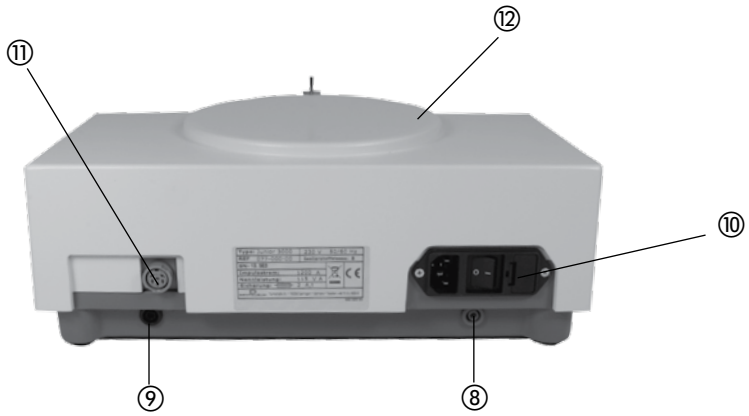

⑧ Outlet for hand electrodes

⑨ Outlet for hand electrodes

⑩ Combination outlet with power-supply switch, power plug and fuse holder

⑪ Outlet for foot switch

⑫ Housing with tray

Contents

1. Manufacturer	5
2. Safety information	5
2.1 Intended use	5
2.2 Danger symbols and markings	5
3 General notes and disposal	6
4. Description and usage	6
4.1 Application	6
5. Technical data	6
6. Components supplied	7
7. Unpacking and start-up procedure	7
8. Operating instructions	7
8.1 Spot welding	7
8.1.1 Spot welding with "click-stop" electrodes	10
8.1.2 Spot welding with hand electrodes (optional accessory)	11
8.2 Soldering	12
8.2.1 Soldering with click-stop electrodes	13
8.2.2 Soldering with hand electrodes (optional accessory)	14
8.3 Heat treatment	15
8.3.1 Annealing of wires	15
8.3.2 Tempering of wires	15
8.3.3 Stress relieving of wires	16
8.3.4 Procedure for soft annealing, tempering and stress relieving	16
9. Troubleshooting	17
10. Dentaurum Customer Service – Equipment	18
11. Care and maintenance	18
12. Spare parts for click-stop holders	18
13. Optional accessories	19
13.1 Spare parts for hand electrodes	20
13.2 Installation of the holder for hand electrodes	21
14. Schematic	22
15. Welding charts	24
15.1 Noninium® wires	24
15.2 remanium® wires	25
15.3 remaloy® wires	26
15.4 rematitan® SPECIAL wires	27
15.5 Other materials	28
16. Quality information	29
17. EC-Declaration of Conformity	30

Dear customer

Thank you for choosing a quality product from Dentaaurum.

It is essential to read these instructions carefully and adhere to them to ensure safe, efficient use and ensure that you and your patients gain full benefit.

Instructions for use cannot describe every eventuality and possible application. In case of questions or ideas, please contact your local representative.

As our products are regularly upgraded, we recommend that you always carefully read the current Instructions for use supplied with the product and stored in the internet at www.dentaaurum.com, even though you may frequently use the same product.

1. Manufacturer

Dentaaurum GmbH & Co. KG | Turnstr. 31 | 75228 Ispringen | Germany

2. Safety information



Caution: Read through the instructions for installing and operating the unit carefully before switching it on. Only then should the unit be switched on.

2.1 Intended use

The Junior 3000 is only intended for the welding and soldering of orthodontic appliances. It is not intended to be used for any other purpose. The use of the unit for its correct purpose includes

- compliance with all the instructions contained in the Instructions for use.

The Junior 3000 is **not** suitable for prosthetics work, in particular not for the processing of

- precious metals alloys
- cast partial denture alloys or non-precious metal alloys for ceramics

When a Dentaaurum product is taken out of operation once and for all, the disposal regulations of the country of operation apply. Dentaaurum or the dental trade is available to answer questions regarding the correct disposal of any specific product.

2.2 Danger symbols and markings

In the Instructions for use, the following symbols are used to indicate sources of danger to the user:



This symbol indicates direct danger to the life or health of the user. Disregarding this warning may involve a serious risk to health.



This symbol indicates important safety instructions. Disregarding this warning may cause damage to the unit and/or other property.



This symbol gives important information on the correct use of the unit. Disregarding this information may cause the unit to malfunction.

3. General notes and disposal



Always wear safety goggles when soldering or welding.

To use the Junior 3000 to its full advantage, study the following notes carefully before using it for the first time.

The unit requires high voltage. In order to avoid accidents, the unit should only be opened by Dentaaurum Customer Service's personnel or authorized service technicians.

When a Dentaaurum product is taken out of operation once and for all, the disposal regulations of the country of operation apply. Dentaaurum or the dental trade is available to answer questions regarding the correct disposal of any specific product.



Note:

This symbol indicates that products with this marking should not be disposed of together with household garbage. The legislator does not allow commercial customers to return electronic waste via municipal collection points. Further information is available from Dentaaurum or specialist dental traders.

4. Description and usage

4.1 Application

The Junior 3000 spot-welding unit fulfils all the requirements for producing optimum weld or solder joints in orthodontic appliances:

- 2-stage setting of welding energy
- Soldering stage with fixed setting
- Ergonomic design
- Outlets for optional accessories

5. Technical data

Mains connection	230 V	50/60 Hz	REF 077-000-00
	115 V	50/60 Hz	REF 077-000-01
Rated power	115 W		
Impulse current	1200 A		
Fuse	2 A, time-delay fuse (for 230 V); 3.15 A, time-delay fuse (for 115 V)		
Insulation class	B		
Dimensions	335 x 310 x 130 mm (13 1/4" x 8" x 5 1/4") (W x D x H)		
Weight	approx. 7 kg/17 lbs		
Color:	housing RAL 9001 white		
Base and hand rest:	RAL 1515 blue		
Manual button:	RAL 9006 white-aluminum		

The rating plate with the number is on the back of the unit.

6. Components supplied

The basic set contains the following items:

Junior 3000 unit

- Power cable
- Screwdriver for changing electrodes
- File for solder electrodes
- 1 x spare fuse
- Instructions for use

7. Unpacking and start-up procedure

Should you notice any damage which may have occurred in transit, notify Dentaureum Customer Service (page 18) or the dealer you got the unit from without delay



Before using the unit, ensure that the power supply voltage corresponds to the operating voltage stated on the rating plate on the back of the unit.

Plug the power cable into the power cable outlet ⑩ and then into the power supply outlet. The unit is now ready for operation.

8. Operating instructions

8.1 Spot welding



Always wear goggles for welding work.



When using the hand electrodes for welding, the electrodes must not touch each other at the electrode holders, otherwise an electric current will flow through the electrode holders and the hand electrodes, and cause poor welding results.







In order to meet the complex requirements for constructing orthodontic appliances, the Junior 3000 is fitted with 7 different copper electrodes for welding. These have special contact tips/surfaces.

The click-stop electrode holders ②, ③ permit quick and easy changing from one electrode to the other. When the holder is turned to the desired position, the electrodes click into the correct position in relation to one another.

Maximum load on unit

If the unit is being used over several hours, only one welding pulse at the most should be activated every 5 seconds.

However, if it is only being used for a few minutes (max. 30 minutes) a pulse can be activate devery second.

Electrode combinations and designs					
for welding:		for welding:		for welding:	
brackets, tubes, hooks and loops		wire to wire		wire to bands	
Upper electrode REF 085-000-00		Upper electrode REF 085-200-00		Upper electrode REF 085-100-00	
Lower electrode REF 086-000-00		Lower electrode REF 086-100-00 or REF 086-300-00		Lower electrode REF 086-200-00	
					

 For recommended welding settings, see separate table (p. 24ff.)

Notes

- Electrodes must always be clean. Clean, polished electrode tips that are correctly positioned are essential for perfect welding.
- Objects being welded must always be free of dirt and grease and have a clean metallic surface.

Polishing the tips

Fold a piece of sandpaper (grain 600) with the rough side outwards and push it between the electrodes. Draw the sandpaper back and forth between the tips until the entire surface of both tips is polished. Remove any burrs which are created on the electrodes. If the electrodes no longer function correctly after a longer period, they can generally be re-worked slightly using the electrode file REF 083-300-00. However, if the size of the electrode tip is affected, replace the electrode with a new one.

Applications

Welding brackets to bands

When welding brackets to band material or pre-formed bands, ensure that the upper electrode is positioned fully on the welding flange of the bracket.

Welding tubes to wire

The wall of the tube must be in contact with the wire. If the pressure of the electrode is not sufficient to make contact, it is suggested flattening the tube slightly at the contact point with pliers.

Spot-welding crossed wires

Where the wires are simply crossed, a single spot-weld is usually adequate to connect them properly. In many cases, it is advisable to solder the wires in addition to welding. In this case, take into account that heating the wires when soldering them to strengthen the joint also causes the mechanical properties of the wires to deteriorate.

Checking a weld

The simplest method is to make a visual check of the weld quality of a specific spot-weld, e.g. a weld-on component (bracket) onto a band. Clearly visible light brown points on the inside of the band indicate a successful weld.

8.1.1 Spot welding with the click-stop electrodes

Procedure

1. Turn power switch ⑭ to position "I". The green pilot light ⑤ turns on. The unit is now ready for use.
2. Press switch ⑥ to position ⑥a to select the "welding" mode.
3. Set the desired welding energy at switch ⑦ (stage I or II)
4. Press hand rest ① down and set the desired combination of copper electrodes on the click-stop electrode holders ② and ③.
5. Press hand rest ① down and insert workpiece. When pressure on the hand rest is reduced, the electrodes close and fix the workpiece in position.

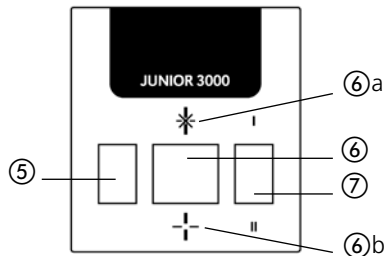

6. Activate the welding pulse with the manual button ④ or foot switch (special accessory). 2-3 adjacent welding pulses are enough to create a perfect welded joint.
7. Release the workpiece by pressing the hand rest ① and repeat the welding process if necessary.
8. After completing the welding process, turn the unit off and turn the power switch ⑩ to position "0".

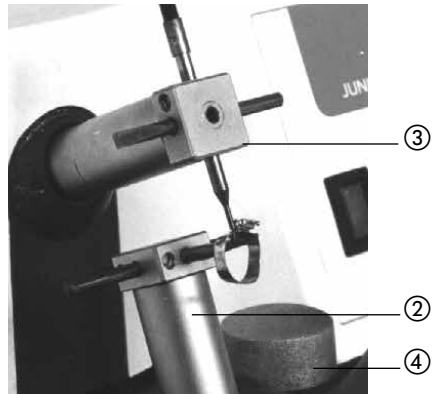

8.1.2 Spot welding with hand electrodes (optional accessory)

This process is recommended when for example wires have to be fixed against one another on the model. The components removed from the model should then be re-welded or soldered at the click-stop electrodes.

Procedure

1. Turn the upper electrode head on the click-stop holder ③ one turn (45°) to the left or the right.



The upper and lower electrodes must not touch each other.

2. Push the plugs of the hand electrodes into the outlets ⑫ and ⑬.
3. Turn power switch ⑭ to position "I". The green pilot light ⑤ turns on. The unit is now ready for use.
4. Press switch ⑥ to position ⑥a to select the "Welding" mode.
5. Set the desired welding energy at switch ⑦ (stage I or II)
6. Clamp a notched electrode REF 081-501-00 into each of the clamping sleeves of the manual electrodes and then touch the workpiece with the notched tips at a short distance from the welding point. The notches of the electrode prevent it from slipping off the wire element.
7. Activate the welding pulse with the manual button ④ or foot switch. 2-3 welding pulses are enough to create a perfect welded joint.
8. After completing the welding process, turn the unit off and turn the power switch ⑩ to position "0".

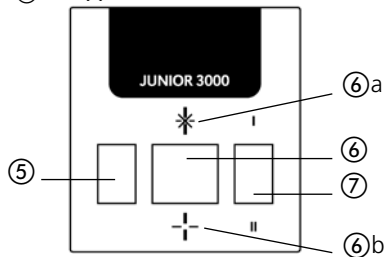

**Note**

When welding with the hand electrodes, the welding power must be set higher (stage 2) than with the click-stop holder. The welding energy setting depends on the cross section of the material being welded. (See separate charts p. 24ff.).

**Recommended accessory:**

Connect foot switch REF 080-116-00 to outlet ⑩.



8.2 Soldering



When soldering, always wear safety goggles. If soldering takes too long, the soldering carbon will be damaged.



When using hand electrodes for soldering or heat-treating, the electrodes must not touch each other at the electrode holders. However, if they do touch one another, a fault signal will be given. If the carbon electrode is used, the current flows through the electrode holder and through the hand electrodes, causing poor soldering results.

- For soldering purposes, one of the copper electrodes is replaced by a carbon electrode (soldering electrode REF 085-300-00). The heat created by the electrical resistance is stored mainly in the carbon tip, whereas the metal parts themselves absorb only a slight amount of heat. The soldering process differs from the welding process by using solder and flux.
- During electric soldering, the carbon electrode leads to continuous heating until the solder is melted. This then flows around the metal parts which are also heated and protected from oxidation by the flux.
- Before soldering, the carbon electrode should be cleaned with the emery file, REF 083-300-00 to remove any flux residues. Such residues have an insulating effect and would hinder the flow of current during the next soldering operation. Replace the carbon electrode **before** the brass sleeve and the electrode shaft begin to char.
- We recommend using a pencil sharpener to sharpen the soldering carbon REF 081-601-00. To increase the conductivity of the soldering carbon, dip the tip in water before beginning the soldering operation.
- The hand electrodes are **not** suitable for continuous soldering.
- The soldering carbon offers more resistance to the current than the clamping electrode REF 081-701-00, thus causing heat to build up in the tip of the soldering carbon. Always ensure that the carbon tip is placed where the heat cannot damage the parts.

Solders

Universal silver solder

Working temperature: 700 °C/1292 °F

..... ready fluxed 1.2 g **REF 380-604-50**

..... without flux 10 g **REF 380-704-50**

Dentaflux®

..... 50 g **REF 681-100-00**

For all types of orthodontic soldering. If necessary, dilute slightly with water.

White gold solder

Working temperature: 950 °C/1742 °F

..... ready fluxed 1.6 g **REF 380-600-50**

8.2.1 Soldering with the click-stop electrodes

First tack weld the parts together with a weld spot.

Procedure

1. Turn power switch ⑩ to position "I". The green pilot light ⑤ turns on.
2. Press switch ⑥ to position ⑥b to select the "soldering" mode. In "soldering" mode, the switch ⑦ has no function.
3. Set the electrodes to combination A or B (cf. fig. below).
4. Apply flux to the section to be soldered and add the solder or apply universal silver soldering paste (REF 380-804-50).
5. Press the hand rest ① down and place the workpiece between the electrodes.
6. Align the carbon electrode on the workpiece without applying pressure.
7. Press the manual button ④ or the foot switch until the solder is melted and the soldering process finished.

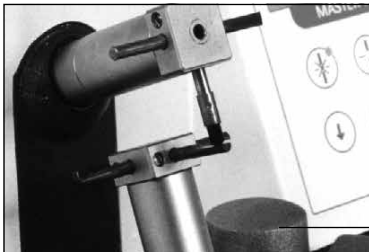
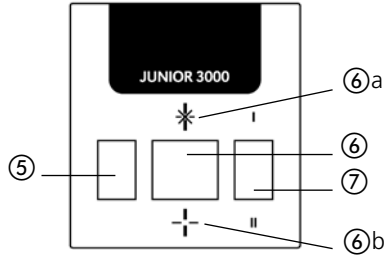

Electrode combination:

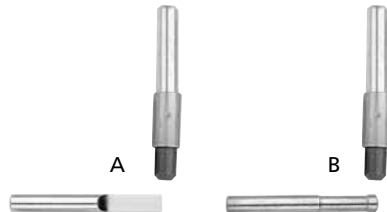

 **Note: Please always use the carbon soldering electrode.**

8.2.2 Soldering with hand electrodes (optional accessory)

Procedure

1. Turn the upper electrode head on the click-stop holder ③ one turn (45°) to the left or the right.

! The upper and lower electrodes must not touch each other.

2. Push the plugs of the hand electrodes into the outlets ⑧ and ⑨.

3. Clamp the electrode REF 081-701-00 for holding the workpiece and clamp the soldering carbon REF 081-601-00 into the clamping sleeve of the right and left hand electrode (cf. fig. below).

4. Turn power switch ⑩ to position "I". The green pilot light ⑤ turns on.

5. Press switch ⑥ to position ⑥b to select the "Soldering" mode. In "soldering" mode, the switch ⑦ has no function.

6. Clamp the tack-welded parts in the clamping electrode as close as possible to the soldering point.

7. Apply flux when using solder in rods or in a roll, e.g. REF 380-604-50, REF 380-600-50 or REF 380-704-50.

8. Place the tip of the soldering carbon as close as possible to the soldering point.

9. Proceed as below a) or b) depending on the type of solder used:

a) Press the foot switch. Apply the solder when the solder joint begins to turn red.

b) Press the foot switch until the solder has completely melted.

10. If the unit is no longer required, turn power switch ⑩ to position "0".

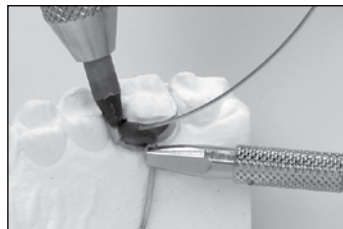
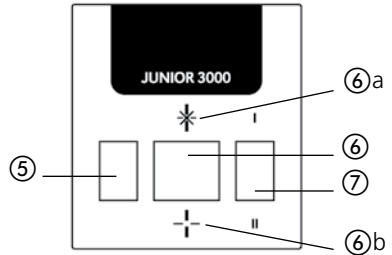

8.3 Heat treatment

8.3.1 Annealing of wires

Spring hard chrome nickel stainless steel wires (e.g. remanium®) can be soft annealed at a temperature of approx. 1100 °C/2012 °F (heat color: bright red).

Soft annealed CoCr wires cannot be tempered (hardened)!

Complex bending operations (especially around tight radii with thick wires, e.g. outer wires of face bows) should not be done without previous local annealing of the bending area. Soft annealing is also recommended for removing the elasticity from a wire over a certain length, e.g. with a passive lingual or palatal bow. Refer to 8.3.4 for the subsequent procedure.



8.3.2 Tempering of wires

Cobalt based alloys, e.g. remaloy®, or Crozat wires can be tempered (hardened). The tempering of the wire elements depends on the time and the temperature. Heat the wire element only briefly using the hand electrodes (heat color: dark brown) at a temperature of approx. 470 °C/878 °F. In view of the different wire dimensions, it is recommended to determine the optimum hardening conditions experimentally beforehand. Refer to 8.3.4 for the subsequent procedure.



8.3.3 Stress relieving of wires

When spring hard wires are bent, stresses are created in their crystalline structure. The bent wire element can be stress relieved using a suitable heat treatment process. This is done by heating the wire to approx. 550 °C / 1022 °F over a short period of time. (heat color: dark red)

Please note that stress relieving of wire elements on the model takes longer as the plaster absorbs a considerable amount of heat. Refer to 8.3.4 for the subsequent procedure.



8.3.4 Procedure for soft annealing, tempering and stress relieving

Important!

1. Turn the upper electrode head on the click-stop holder ③ one turn (45°) to the left or the right.

! The upper and lower electrodes must not touch each other. Should they touch, a fault signal will be given.

2. Fit the hand electrodes into outlet ⑧ and ⑨ and clamp the notched electrodes REF 081-501-00 into the clamping sleeves.

3. Connect the foot switch to outlet ⑪.

4. Turn power switch ⑩ to position "I". The green pilot light ⑤ turns on.

5. Press switch ⑥ to position ⑥b to select the "Soldering" mode. In "Soldering" mode, the switch ⑦ has no function.

6. Set the notched electrode tips in the area of the wire to be heat treated.

7. Operate the foot switch until the wire has reached the temperature (color) for the desired heat treatment process.

Bright red	approx. 1100 °C / 2012 °F	soft annealing
Dark red	approx. 550 °C / 1022 °F	stress relieving
Dark brown	approx. 470 °C / 878 °F	tempering

8. Remove the electrodes quickly from the wire. Release the foot switch.

9. On completion of heat treatment, turn the power switch ⑩ to position "0".

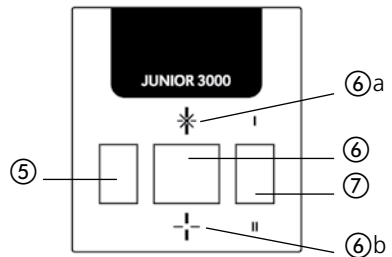

 **Note:**

- To soft anneal thick wires, we recommend placing these on a conductive, heat-resistant base, e.g. a graphite slab.
- Instead of the notched electrode REF 081-501-00, the clamping electrode REF 081-701-00 can be used in a hand electrode to hold the wire element.
- To practice the techniques necessary for soft annealing, tempering and stress relieving, we recommend experimenting with the different kinds of wire.



Caution: With thin wires only press the foot switch briefly to ensure the wires do not burn or melt!

9. Troubleshooting

Fault	Cause	Remedy
1.0 Unit switched on but nothing appears in display	1.1 Not connected to power supply	1.1.1 Connect unit to power supply 1.1.2 Check fuse at power outlet
	1.2 Unit fuse defective	1.2.1 Replace fuse. *To change fuse (see below)
2.0 Welding and soldering power set too low	2.1 Electrodes or solder carbon dirty or worn	2.1.1 Clean or replace electrodes or solder carbon  The electrodes must be positioned flat in relation to each other
3.0 Welding power set too low	3.1 Welding power on unit set too low	3.1.1 Set switch ⑦ to stage II



The unit operates under high voltage!

To prevent accidents, never open the unit. If malfunctions cannot be corrected as described above, please contact Dentaaurum Customer Service (see page 18).

***Replacing the fuse:**

Unlock the fuse insert on the right-hand side of the combination plug ⑩ and pull it out.

The fuse is now accessible and can be removed from the fuse holder.



Pull out the power plug before removing the fuse holder!

10. Dentaureum Customer Service - Equipment

Dentaureum Customer Service - Equipment

Dentaureum GmbH & Co. KG | Turnstr. 31 | 75228 Ispringen | Germany
(P.O.B. 100 440, 75104 Pforzheim)



Tel. +49 72 31/803-211 | Fax +49 72 31/803-295 | info@dentaureum.com

11. Care and maintenance

The unit requires no maintenance.

Only the copper electrodes require filing after use. The copper electrodes should be cleaned to remove any flux residues.









If necessary, wipe the cover with a dry or damp cloth. Do not use corrosive cleaning agents!

 **Do not place hot objects in the tray** .

12. Spare parts for "click-stop" holders

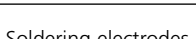

Upper electrodes

Lower electrodes

	REF 085-000-00 1 piece		REF 086-000-00 1 piece
	REF 085-100-00 1 piece		REF 086-100-00 1 piece
	REF 085-200-00 1 piece		REF 086-200-00 1 piece
	REF 085-300-00 1 piece		REF 086-300-00 1 piece

Soldering electrodes

Spare carbon insert for soldering electrode

	REF 085-300-00 1 piece		REF 086-400-00 10 pieces
---	---------------------------	---	-----------------------------

Screws for tightening electrodes

	REF 084-100-00
	10 pieces

Spare fuse 3,15 A, time-delay fuse (for 115 V)

	REF 907-037-10
	1 piece

Spare fuse 2 A, time-delay fuse (for 230 V)

	REF 907-047-10
	1 piece

Screwdriver
for changing electrodes



REF 083-100-00
1 piece

Emery file
for soldering carbon



REF 083-300-00
10 pieces

13. Optional accessories

Foot or knee switch, combined



REF 080-116-00	1 piece
----------------	---------

Holder for hand electrode



REF 081-204-00	1 pair
REF 081-205-00	Holder, right
REF 081-206-00	Holder, left

Hand electrode, single



REF 081-101-00	1 piece
----------------	---------

13.1 Spare parts for hand electrodes

Soldering carbon with copper jacket for hand electrode	
	
REF 081-601-00	1 piece

Electrodes, notched for annealing, tempering, welding	
	
REF 081-501-00	2 pieces

Clamping electrode	
	
REF 081-701-00	1 piece

13.2 Installation of the holder for hand electrodes

REF 081-204-00/081-205-00/081-206-00

Tools required: Phillips screwdriver



Turn the welding unit upside down.



Do not place the welding unit on the electrodes.



Installation of the electrode holder.



Connect the hand electrodes and place them into the holder.



14. Schematic

Fittings for various voltage variants:

- | | | |
|-------|----|-----------------|
| 230 V | C1 | 220u/400V |
| | C2 | 100u/400V |
| | R3 | 820R/1W |
| | R5 | 68k |
| | C3 | nicht bestueckt |
| | | 2 AT |
| 115 V | C1 | 470u/250V |
| | C2 | 220u/250V |
| | C3 | 220u/250V |
| | R3 | 270R/0.5W |
| | R5 | 33k |
| | | 3.15 AT |

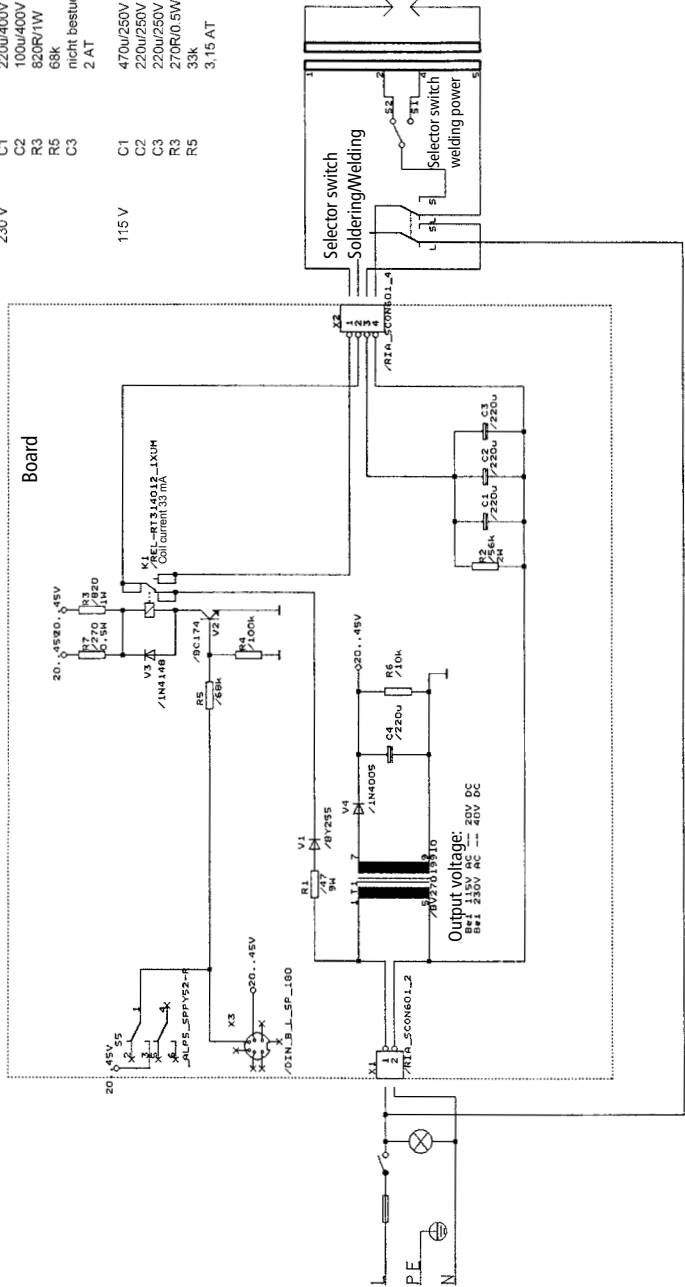

N° – Name	
1 – Fuse 2 At (for 230V).....	907-047-10
Fuse 3,15 At (for 115 V).....	907-037-10
2 – Unit base	908-868-00
3 – Power cable	907-027-10
4 – Control-power board (230 V).....	908-624-00
Control-power board (115 V).....	908-624-10
5 – Control light (230 V).....	907-443-00
Control light (115 V).....	907-447-00
6 – Change-over switch, double pole.....	908-765-00
7 – Change-over switch, double pole.....	908-765-10
8 – Relay.....	908-624-50
9 – Resistor 47 Ω	908-138-00
10 – Diode.....	907-214-00

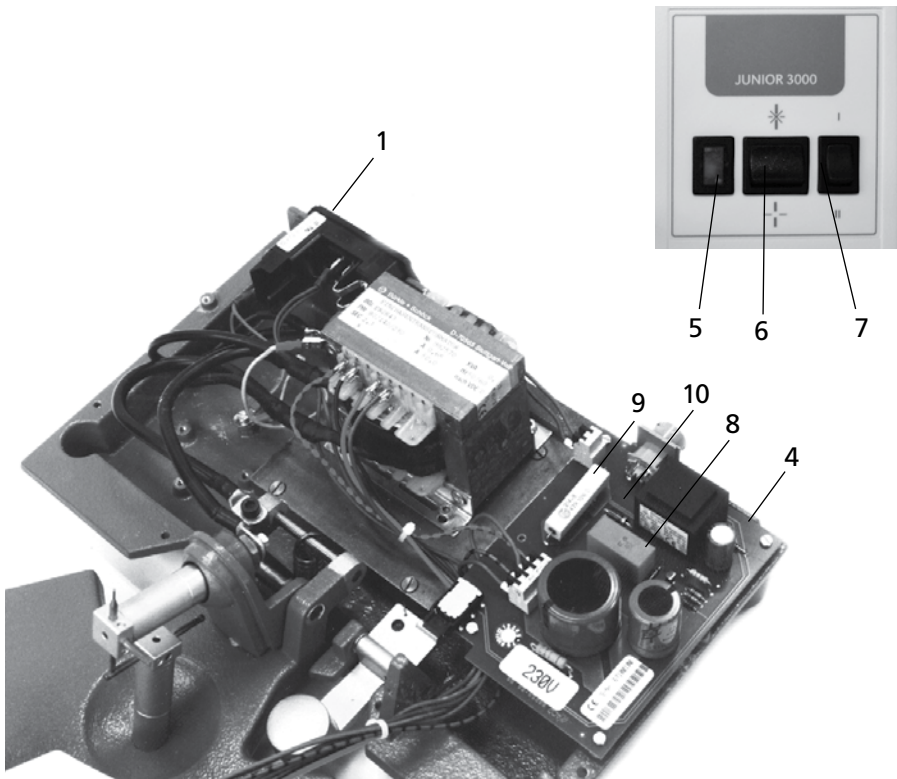

15. Welding charts

The following charts provide a list of settings of the weld energy for different materials.

Different settings may be required depending on the specific application and materials as well as the condition of the surface!

15.1 Noninium® wires

Material 1	Material 2	Electrode combination	Setting Junior 3000	Setting Assistant 3000	Setting Master 3000
Noninium® wire 0.7 mm hard REF 520-070-00	Noninium® wire 0.7 mm hard REF 520-070-00	REF 085-200-00 and REF 086-100-00	Stage 2	Stage 3 – 4	46 – 48
Noninium® wire 0.7 mm hard REF 520-070-00	Noninium® wire 0.8 mm hard REF 520-080-00	REF 085-200-00 and REF 086-100-00	Stage 2	Stage 4 – 5	48 – 50
Noninium® wire 0.8 mm hard REF 520-080-00	Noninium® wire 0.8 mm hard REF 520-080-00	REF 085-200-00 and REF 086-100-00	Stage 2 tack welding	Stage 4 – 5	62 – 64
Noninium® wire 0.8 mm hard REF 520-080-00	Noninium® wire 0.9 mm hard REF 520-090-00	REF 085-200-00 and REF 086-100-00	Stage 2 tack welding	Stage 4 – 5	64 – 66
Noninium® wire 0.9 mm hard REF 520-090-00	Noninium® wire 0.9 mm hard REF 520-090-00	REF 085-200-00 and REF 086-100-00	Stage 2 tack welding	Stage 6	75 – 77
Noninium® wire 0.9 mm hard REF 520-090-00	Noninium® wire 1.2 mm hard REF 520-120-00	REF 085-200-00 and REF 086-100-00	Stage 2 tack welding	Stage 6	77 – 79
Noninium® wire 1.2 mm hard REF 520-120-00	Noninium® wire 1.2 mm hard REF 520-120-00	REF 085-200-00 and REF 086-100-00	Stage 2 tack welding	Stage 6 tack welding	88 tack welding
Noninium® wire 0.7 mm spring hard REF 520-072-00	Noninium® wire 0.7 mm spring hard REF 520-072-00	REF 085-200-00 and REF 086-100-00	Stage 2	Stage 4	45 – 47
Noninium® wire 0.7 mm spring hard REF 520-072-00	Noninium® wire 0.8 mm spring hard REF 520-082-00	REF 085-200-00 and REF 086-100-00	Stage 2	Stage 5	49 – 51
Noninium® wire 0.8 mm spring hard REF 520-082-00	Noninium® wire 0.8 mm spring hard REF 520-082-00	REF 085-200-00 and REF 086-100-00	Stage 2 tack welding	Stage 5	57 – 59
Noninium® wire 0.8 mm spring hard REF 520-082-00	Noninium® wire 0.9 mm spring hard REF 520-092-00	REF 085-200-00 and REF 086-100-00	Stage 2 tack welding	Stage 6	71 – 73
Noninium® wire 0.9 mm spring hard REF 520-092-00	Noninium® wire 0.9 mm spring hard REF 520-092-00	REF 085-200-00 and REF 086-100-00	Stage 2 tack welding	Stage 6	77 – 79

15.2 remanium® wires

Material 1	Material 2	Electrode combination	Setting Junior 3000	Setting Assistant 3000	Setting Master 3000
remanium® wire 0.7 mm hard REF 513-070-00	remanium® wire 0.7 mm hard REF 513-070-00	REF 085-200-00 and REF 086-100-00	Stage 2 tack welding	Stage 5	59 – 61
remanium® wire 0.7 mm hard REF 513-070-00	remanium® wire 0.8 mm hard REF 513-080-00	REF 085-200-00 and REF 086-100-00	Stage 2 tack welding	Stage 5	61 – 63
remanium® wire 0.8 mm hard REF 513-080-00	remanium® wire 0.8 mm hard REF 513-080-00	REF 085-200-00 and REF 086-100-00	Stage 2 tack welding	Stage 6	81 – 83
remanium® wire 0.8 mm hard REF 513-080-00	remanium® wire 0.9 mm hard REF 513-090-00	REF 085-200-00 and REF 086-100-00	Stage 2 tack welding	Stage 4 – 5	85 – 87
remanium® wire 0.9 mm hard REF 513-090-00	remanium® wire 0.9 mm hard REF 513-090-00	REF 085-200-00 and REF 086-100-00	Stage 2 tack welding	Stage 6 tack welding	88
remanium® wire 0.5 mm spring hard REF 523-050-00	remanium® wire 0.5 mm spring hard REF 523-050-00	REF 085-200-00 and REF 086-100-00	Stage 2	Stage 3 – 4	35 – 40
remanium® wire 0.5 mm spring hard REF 523-050-00	remanium® wire 0.6 mm spring hard REF 523-060-00	REF 085-200-00 and REF 086-100-00	Stage 2	Stage 3 – 4	43 – 47
remanium® wire 0.6 mm spring hard REF 523-060-00	remanium® wire 0.6 mm spring hard REF 523-060-00	REF 085-200-00 and REF 086-100-00	Stage 2 tack welding	Stage 4	47 – 50
remanium® wire 0.6 mm spring hard REF 523-060-00	remanium® wire 0.7 mm spring hard REF 523-070-00	REF 085-200-00 and REF 086-100-00	Stage 2 tack welding	Stage 4	47 – 50
remanium® wire 0.7 mm spring hard REF 523-070-00	remanium® wire 0.7 mm spring hard REF 523-070-00	REF 085-200-00 and REF 086-100-00	Stage 2 tack welding	Stage 4 – 5	60 – 63
remanium® wire 0.7 mm spring hard REF 523-070-00	remanium® wire 0.8 mm spring hard REF 523-080-00	REF 085-200-00 and REF 086-100-00	Stage 2 tack welding	Stage 6	63 – 65
remanium® wire 0.8 mm spring hard REF 523-080-00	remanium® wire 0.8 mm spring hard REF 523-080-00	REF 085-200-00 and REF 086-100-00	Stage 2 tack welding	Stage 6	73 – 78
remanium® wire 0.8 mm spring hard REF 523-080-00	remanium® wire 0.9 mm spring hard REF 523-090-00	REF 085-200-00 and REF 086-100-00	–	Stage 6 tack welding	78 – 80
remanium® wire 0.9 mm spring hard REF 523-090-00	remanium® wire 0.9 mm spring hard REF 523-090-00	REF 085-200-00 and REF 086-100-00	–	Stage 6 tack welding	88

15.3 remaloy® wires

Material 1	Material 2	Electrode combination	Setting Junior 3000	Setting Assistant 3000	Setting Master 3000
remaloy® wire 0.7 mm hard REF 528-070-00	remaloy® wire 0.8 mm hard REF 528-080-00	REF 085-200-00 and REF 086-100-00	Stage 2	Stage 3 – 4	35 – 40
		Hand electrodes REF 081-501-00	–	Stage 6 tack welding	61 – 63 tack welding
remaloy® wire 0.7 mm hard REF 528-070-00	remaloy® wire 1.0 mm hard REF 528-100-00	REF 085-200-00 and REF 086-100-00	Stage 2	Stage 6	40 – 45
		Hand electrodes REF 081-501-00	–	Stage 6 tack welding	65 – 67 tack welding
remaloy® wire 0.8 mm hard REF 528-080-00	remaloy® wire 1.0 mm hard REF 528-100-00	REF 085-200-00 and REF 086-100-00	–	Stage 6 tack welding	73 – 75 tack welding
		Hand electrodes REF 081-501-00	–	Stage 6 tack welding	73 – 75 tack welding
remaloy® wire 0.9 mm hard REF 528-090-00	remaloy® wire 0.9 mm hard REF 528-090-00	REF 085-200-00 and REF 086-100-00	–	Stage 6 tack welding	45 – 50
		Hand electrodes REF 081-501-00	–	Stage 6 tack welding	79 – 81 tack welding
remaloy® wire 0.9 mm hard REF 528-090-00	remaloy® wire 1.3 mm hard REF 528-130-00	REF 085-200-00 and REF 086-100-00	–	Stage 6 tack welding	50 – 55
		Hand electrodes REF 081-501-00	–	Stage 6 tack welding	83 – 86 tack welding

15.4 rematitan® SPECIAL wires

Material 1	Material 2	Electrode combination	Setting Junior 3000	Setting Assistent 3000	Setting Master 3000
rematitan® SPECIAL wire 0.4 mm REF 766-600-00	rematitan® SPECIAL wire 0.4 mm REF 766-600-00	REF 085-200-00 and REF 086-300-00	Stage 1	Stage 1	8 – 10
rematitan® SPECIAL wire 0.4 mm REF 766-600-00	rematitan® SPECIAL wire 0.45 mm REF 766-601-00	REF 085-200-00 and REF 086-300-00	Stage 1	Stage 1	10 – 12
rematitan® SPECIAL wire 0.45 mm REF 766-601-00	rematitan® SPECIAL wire 0.45 mm REF 766-601-00	REF 085-200-00 and REF 086-300-00	Stage 1	Stage 2 – 2	13 – 15
rematitan® SPECIAL wire 0.45 mm REF 766-601-00	rematitan® SPECIAL wire 0.41 x 0.56 mm REF 766-602-00	REF 085-200-00 and REF 086-300-00	Stage 1	Stage 2	19 – 22
rematitan® SPECIAL wire 0.45 mm REF 766-601-00	rematitan® SPECIAL wire 0.43 x 0.64 mm REF 766-603-00	REF 085-200-00 and REF 086-300-00	Stage 1	Stage 2	24 – 26
rematitan® SPECIAL wire 0.45 mm REF 766-601-00	rematitan® SPECIAL wire 0.48 x 0.64 mm REF 766-604-00	REF 085-200-00 and REF 086-300-00	Stage 2 tack welding	Stage 2	22 – 24
rematitan® SPECIAL wire 0.43 x 0.64 mm REF 766-603-00	rematitan® SPECIAL wire 0.43 x 0.64 mm REF 766-603-00	REF 085-200-00 and REF 086-300-00	Stage 2	Stage 2 – 3	40 – 45
rematitan® SPECIAL wire 0.43 x 0.64 mm REF 766-603-00	rematitan® SPECIAL wire 0.48 x 0.64 mm REF 766-604-00	REF 085-200-00 and REF 086-300-00	Stage 2 tack welding	Stage 3	40 – 45
rematitan® SPECIAL wire 0.43 x 0.64 mm REF 766-604-00	rematitan® SPECIAL wire 0.48 x 0.64 mm REF 766-604-00	REF 085-200-00 and REF 086-300-00	Stage 2 tack welding	Stage 3	45 – 47

15.5 Other materials

Material 1	Material 2	Electrode combination	Setting Junior 3000	Setting Assistant 3000	Setting Master 3000
hyrax® II 12/10 REF 602-808-00	Standard biscup bands REF 860-012-00	Hand electrodes REF 081-501-00	-	Stage 5 tack welding	78 – 80 tack welding
	Dentadorm® Snap First molar bands REF 878-013-00 or REF 879-013-00			Stage 6 tack welding	88 tack welding
Goshgarian Palatal bars 0.9 mm REF 728-020-00	Standard biscup bands REF 860-012-00	Hand electrodes REF 081-501-00	-	Stage 6 tack welding	69 – 71 tack welding
	Dentadorm® Snap First molar bands REF 878-013-00 or REF 879-013-00				
remanium® Quad Helix REF 728-100-01	Standard biscup bands REF 860-012-00	Hand electrodes REF 081-501-00	-	Stage 6 tack welding	69 – 71 tack welding
	Dentadorm® Snap First molar bands REF 878-013-00 or REF 879-013-00				
Lingual-/ Palatal sheats REF 728-110-00	Dentaform® Snap II Band REF 881-226-00	REF 085-200-00 and REF 086-300-00	Stage 2	Stage 4	55 – 60
Buttons, short REF 750-401-00	Dentaform® Snap II Band REF 881-226-00	REF 085-200-00 and REF 086-300-00	Stage 2	Stage 4	55 – 60
Lingual hooks REF 750-701-00	Dentaform® Snap II band REF 881-226-00	REF 085-200-00 and REF 086-300-00	Stage 2	Stage 4	55 – 60
Lingual button hooks REF 750-701-00	Dentaform® Snap II band REF 881-226-00	REF 085-200-00 and REF 086-300-00	Stage 2	Stage 4	55 – 60
55 – 60	Buccal tubes convertible REF 724-013-00	REF 085-200-00 and REF 086-300-00	Stage 2	Stage 4	55 – 60

16. Quality information

Dentaurum ensures a faultless quality of the products manufactured by us. These recommendations are based upon our own experiences. The user is responsible for the processing of the products. Responsibility for failures cannot be taken, as we have no influence on the processing on site.

17.

EC-Declaration of Conformity

DENTAURUM GmbH & Co. KG
Turnstr. 31
75228 Ispringen

hereby declares that the design and construction of the laboratory equipment described below, including the version marketed by us, comply with the basic regulations governing safety and health as stated in the EC Guidelines. This declaration will become invalid if the laboratory equipment is modified or altered in any way without our prior consent.

Unit: **Junior 3000 (REF 077-000-00 / 077-000-01)**

Description of unit: Orthodontic spot welder and solderer

Start with unit No.: 102-001 / 103-001

EC guidelines: 73/023/EEC Electrical equipment used within certain voltage limits

89/336/EEC Electromagnetic compatibility
92/031/EEC Modified Guideline

93/068/EEC Modifications of the above guidelines

Applied unified standards: EN 55011/B
EN 61000-4-2/4

Date and manufacturers signature: 01.01.2010
Signatory:



- i.V. Dipl. Ing. (FH) K. Merkle -
Production Manager Mechanic

Printing Date: 27.10.15

Dentaurum Group

Germany | Benelux | España | France | Italia | Switzerland | Australia | Canada | USA
and in more than 130 countries worldwide.



DENTAURUM
QUALITY
WORLDWIDE
UNIQUE

- ➔ For more information on our products and services,
please visit www.dentaurum.com

Date of information: 03/17

Subject to modifications

989-501-02 Printed by Dentaurum Germany 03/17/B/R/1-11

D
DENTAURUM